



H9D

D.C MOTOR STANDARD TYPE

H9D SERIES 120W~200W

DIMENSION

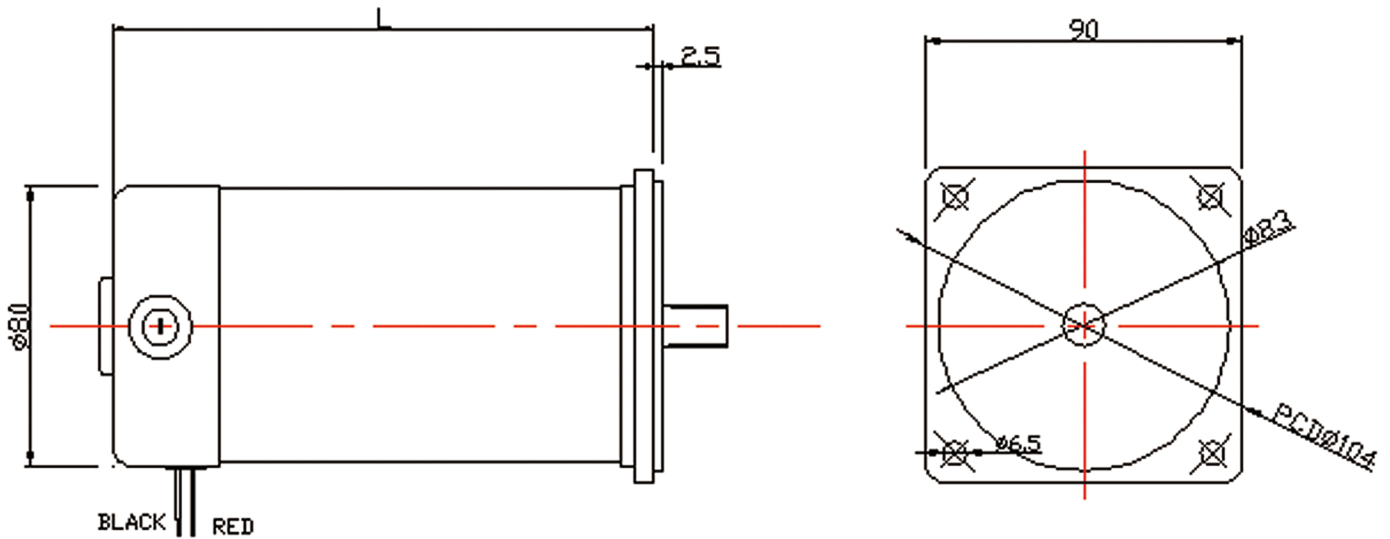

SHAFT 출력축사양 - (표1)

MODEL	GEARED TYPE	STRAIGHT TYPE	D-CUT TYPE	KEY TYPE
	H9D□ - □G	H9D□ - □S	H9D□ - □D	H9D□ - □K
출력축 구분				

MOTOR SPECIFICATION

MODEL	VOLTAGE (V)	OUTPUT (W)	CURRENT (A)	SPEED (RPM)	TORQUE (kgf-cm)	SPEED (RPM)	TORQUE (kgf-cm)	LENGTH L(mm)
H9D12 - 120□	12	120	14	3000	3.89	1-1000	11.6-300	155
H9D12 - 150□	12	150	17.6	3000	4.9	1-1000	14.7-300	155
H9D24 - 120□	24	120	7	3000	3.89	1-1000	11.6-300	155
H9D24 - 150□	24	150	8.8	3000	4.9	1-1000	14.7-300	155
H9D90 - 120□	90	120	1.8	3000	3.89	1-1000	11.6-300	155
H9D90 - 150□	90	150	2.35	3000	4.9	1-1000	14.7-300	155
H9D90 - 200□	90	200	3.14	3000	6.5	1-1000	19.5-300	175
H9D180 - 120□	180	120	0.94	3000	3.89	1-1000	11.6-300	155
H9D180 - 150□	180	150	1.17	3000	4.9	1-1000	14.7-300	155
H9D180 - 200□	180	200	1.57	3000	6.5	1-1000	19.5-300	175