

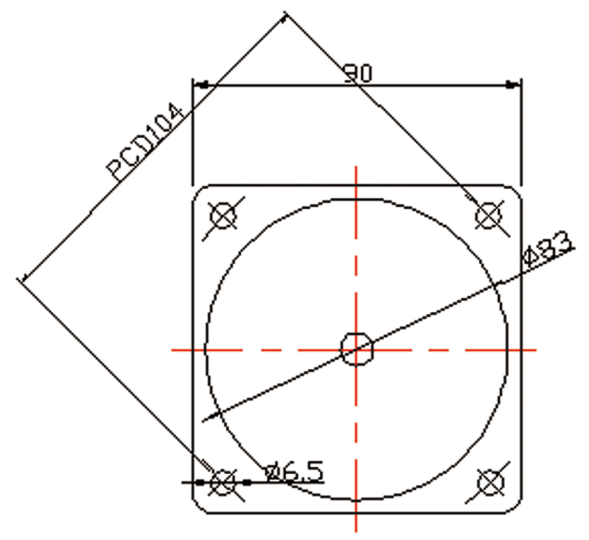

## D.C MOTOR STANDARD TYPE

# H9D SERIES 60W~90W

### DIMENSION

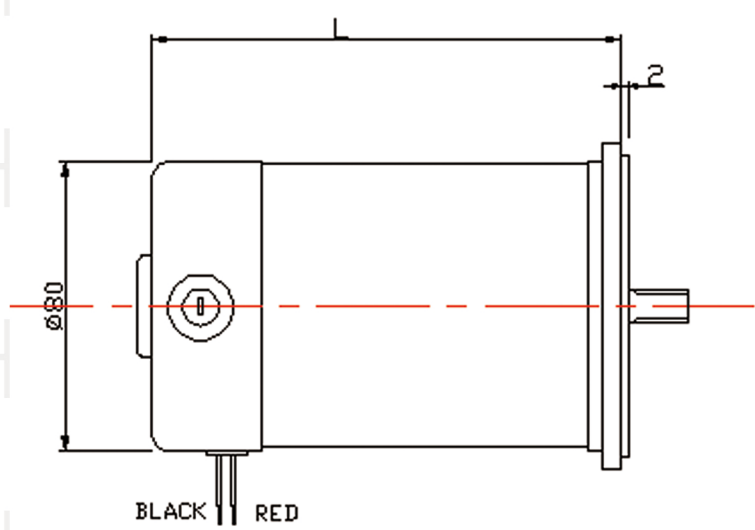

### SHAFT 출력축사양 - (표1)

MODEL	GEARED TYPE	STRAIGHT TYPE	D-CUT TYPE	KEY TYPE
	H9D□ - □G	H9D□ - □S	H9DC - □D	H9D□ - □K
출력축 구분				

### MOTOR SPECIFICATION

MODEL	VOLTAGE (V)	OUTPUT (W)	CURRENT (A)	SPEED (RPM)	TORQUE (kgf-cm)	SPEED (RPM)	TORQUE (kgf-cm)	LENGTH L(mm)
H9D12 - 60□	12	60	7	3000	1.9	1-1000	5.7-100	129
H9D12 - 90□	12	90	10.6	3000	2.9	1-1000	8.7-100	129
H9D24 - 60□	24	60	3.5	3000	1.9	1-1000	5.7-100	129
H9D24 - 90□	24	90	5.3	3000	2.9	1-1000	8.7-100	129
H9D90 - 60□	90	60	0.94	3000	1.9	1-1000	5.7-100	129
H9D90 - 90□	90	90	1.4	3000	2.9	1-1000	8.7-100	129
H9D180 - 60□	180	60	0.47	3000	1.9	1-1000	5.7-100	129
H9D180 - 90□	180	90	0.7	3000	2.9	1-1000	8.7-100	129